

Self-piercing round clinch nuts for heavy metal applications.

- Available in 6mm to 12mm thread sizes
- Automatically fed
- Pierce metal up to 5.15mm and can be used in all areas of the vehicle
- Secure, permanent installation with high torque characteristics
- Available in bulk form
- Meet ISO Class 10 requirements

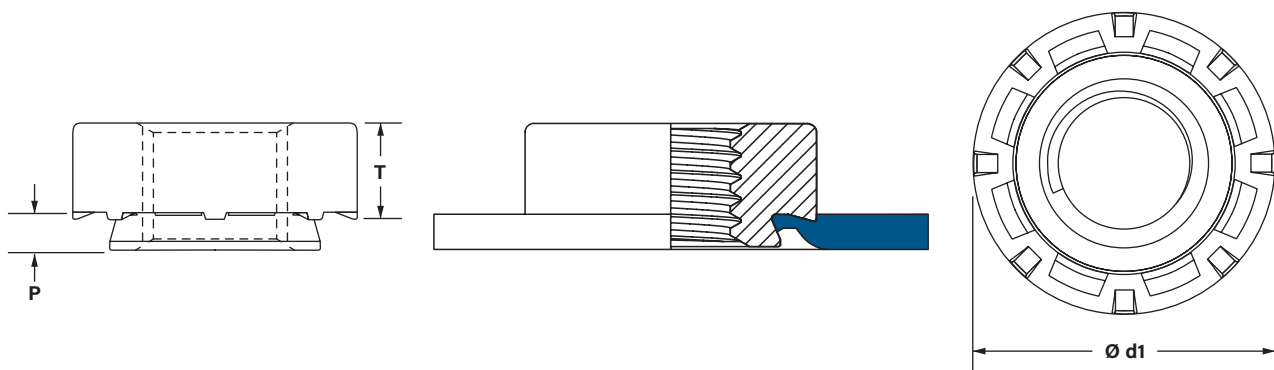

Dimensions are in millimeters

Clinch Nut Series	Part Number	Thread Size (6g tolerance)	Property Class Grade	Metal Range	Installation Load (Tons)	Ø d1 Nut Diameter (Max.)	T Nut Thickness (Max.)	P (Ref.)
MHD06	MD6M16201	M6 x 1.0	10	1.60 - 2.00	20	13.65	3.90	1.45
	MD6M20271			2.01 - 2.75	20			1.85
	MD6M27351			2.76 - 3.50	20			2.60
MHD08	MD8M16201	M8 x 1.25	10	1.60 - 2.00	23	16.75	5.30	1.45
	MD8M20271			2.01 - 2.75	25			1.85
	MD8M27351			2.76 - 3.50	30			2.60
MHD10	MD1M20271	M10 x 1.5	10	2.00 - 2.75	20	19.8	6.35	1.85
	MD1M27351			2.76 - 3.50	25			2.60
	MD1M35431			3.51 - 4.25	25			3.35
MHD12	MD2M25321	M12 x 1.75	10	2.50 - 3.25	35	25.15	7.05	2.35
	MD2M32401			3.26 - 4.05	35			3.10
	MD2M40511			4.06 - 5.15	35			3.90

INSTALLATION

1 The Clinch Nut is automatically placed in position in the installation tool (head) until the metal panel is in position with the die button underneath.

2 As the die closes, the plunger pushes the nut through the metal panel. The pilot area of the nut serves as the punch - virtually a new punch with every cycle of the press.

3 The die button forms the metal panel to lock the nut in place. The die-stamped blank (slug), cut by the pilot of the nut and assisted by the slug rod, drops through the die button as scrap.

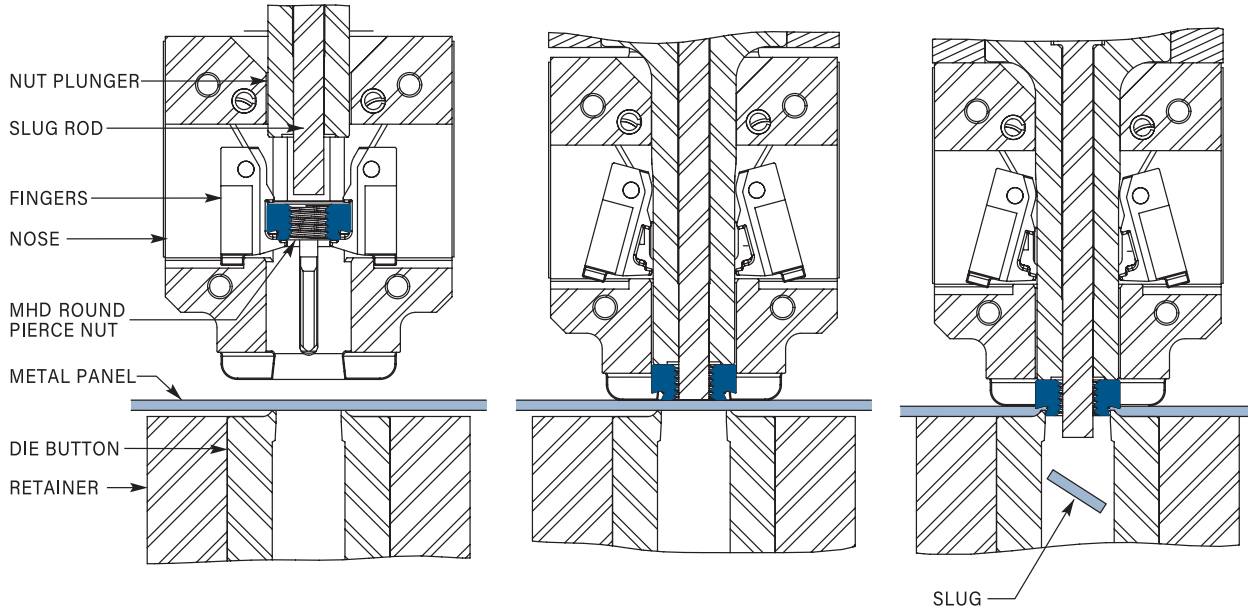

OPERATION

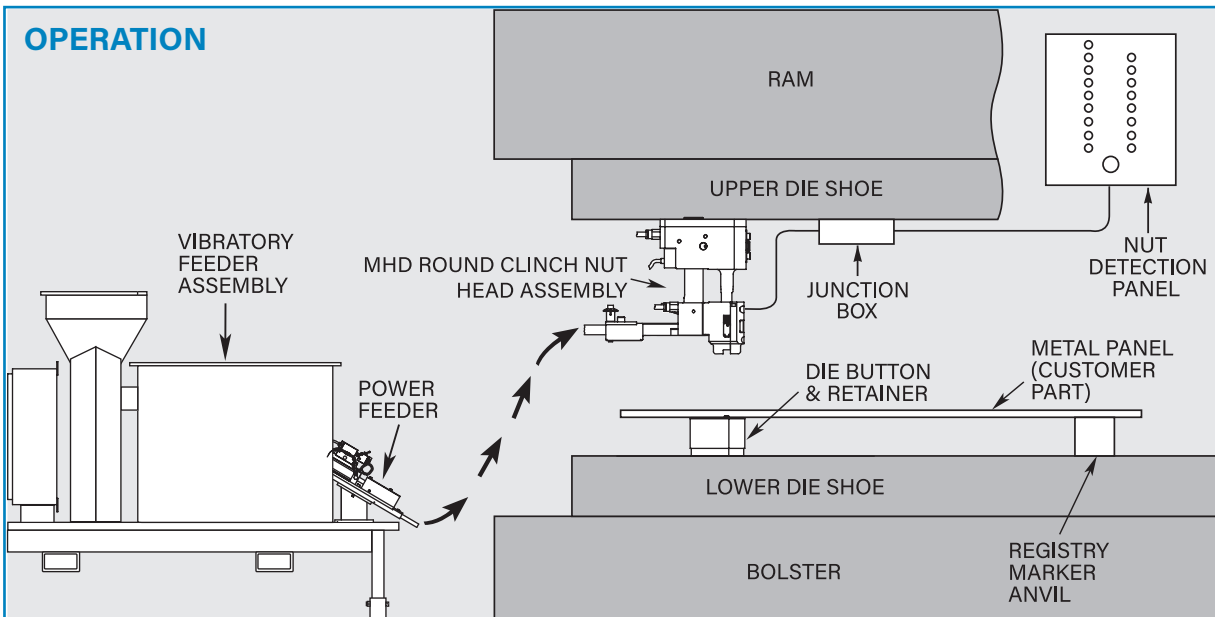

All products meet our stringent quality standards. If you require additional industry or other specific [quality certifications](#), special procedures and/or part numbers are required. Please contact your local sales office or representative for further information.

Regulatory [compliance information](#) is available in Technical Support section of our website. Specifications subject to change without notice. See our website for the most current version of this bulletin.